

Portable Air Purification System

Read manual carefully for proper use and optimal operation.

General Information

Product Overview

Congratulations on your purchase! Your new activTek Pure & Clean+ Ozone utilizes our powerful PCO-A (Photocatalytic Oxidation - Advanced) Technology and other complementary technologies, to provide 24/7 air purification in indoor spaces up to 2,000 sq. ft. Please read and follow all safety warnings and instructions outlined in this owner's manual, before operating or performing maintenance.

Contents

Product Overview	2
Specifications	2
Storage and Disposal	2
Important Safety Instructions	3
Inspection	4
Product Features	4
Settings & Notifications	5
LED Display	6
Directions for Use	6
Maintenance Reminders	7
General Maintenance	8
Filter Assembly	10
Replacing the Filter Assembly	10
Removing the Optional HEPA Filter Sheet	11
PCO-A Cell Assembly	11
Replacing the Purification Plate & PCO-A Cell Assembly	12
Troubleshooting	14
Replacement Parts	15
Warranty Information	16
FCC Declaration & Responsible Party	17

Specifications

activTek Pure & Clean+ Ozone _____

- Sales Number: 00747
- Model Number: A1041A

DOES NOT meet California requirements and cannot be shipped to California or Canada

Technology _____

- PCO-A (Photocatalytic Oxidation - Advanced) Technology - (1) 6" Cell Assembly
- Activated Carbon Filter
- HEPA Filter Screen
- Carbon Brushes
- Purification Plate (O₃)

Electrical _____

- Input Voltage: 100-240 Volts; 50/60 Hz
- Power: 43 Watts Max
- External Power Supply: DC 24 Volts; 1.5 Amps

Mechanical _____

- Nominal Airflow Rate: 40-60 CFM
- Adjustable Speed Fan

Weight & Dimensions _____

- 7.6 lbs
- 11.8" H x 9.5" W x 10" D

Operating Temperature _____

- 34°F – 100°F

Sound Level _____

- 45 dB(A) on low; 55 dB(A) on high

Purification Plate Output (Depart Room Mode) _____

- > 2.0 ppm ozone (O₃)

Coverage _____

- Up to 2,000 sq. ft. with uniform air diffusion¹

Warranty _____

- Limited three (3) year warranty
- Terms and conditions may apply

We reserve the right to change or modify any specification without notice.

¹ Recommended ceiling height to not exceed 10 feet. Solutions should be customized based upon a variety of factors including HVAC system capabilities and settings, air flows taking into account walls, air pressure, and doors, ambient air temperatures and humidities, variable occupant density, known VOC concentrations, and other layers of protection.

Fill In and Save

Record information regarding your new activTek Pure & Clean+ Ozone here. Retain for future reference.

Model No. _____ Serial No. _____ Date of Purchase _____

Name: _____ Phone No. _____

Address: _____

Sales Representative: _____

Storage and Disposal

Do not dispose of this product as household waste. Electrical waste and electronic products should be appropriately recycled as required by practices established by your local authority.



If you have any questions regarding the use of this product, please contact your Sales Representative or Customer Service at 866.736.0503 or email support@activTek.net.

Important Safety Instructions



- Eye damage may result from directly viewing the light produced by the lamp used in this product; always turn off & unplug unit before removing filters or bulbs
- DO NOT operate this unit without the Filter Assembly and Back Cover installed
- Disconnect Power Cord before servicing
- When using electrical appliances, basic precautions should always be followed to reduce risk of fire, electric shock, and injury to persons, including the following:



- Allow your activTek Pure & Clean+ Ozone to warm to room temperature before operating; damage may result from turning on a cold unit
- DO NOT operate unit near heat sources, open flame, or combustible vapors or gases
- The Depart Room Mode feature of this unit is to be operated in unoccupied areas only; no people or pets should be in the area

Read this manual in its entirety before using your activTek Pure & Clean+ Ozone.

Keep out of the reach of children.

- NEVER place your unit where it may fall into a bathtub or other water container; to protect against electrical hazards, DO NOT immerse in water or other liquids
- DO NOT touch the control panel or plug with wet hands
- DO NOT run cord under carpeting; DO NOT cover cord with throw rugs, runners, or similar coverings; arrange cord away from traffic area and where it will not be tripped over
- DO NOT insert or allow foreign objects to enter any ventilation or exhaust opening as this may cause an electric shock or fire, or damage the air cleaner
- To prevent a possible fire, DO NOT block the air intakes or exhaust in any manner; DO NOT use on soft surfaces, like a bed, where openings may become blocked
- To avoid fire or shock hazard, plug the unit directly into an electrical outlet
- To disconnect the unit, turn controls to OFF, then remove plug from outlet; pull firmly on the plug, DO NOT unplug by pulling on the cord
- Always unplug the unit before moving or cleaning, or whenever the unit is not in use
- DO NOT use outdoors or on wet surfaces
- DO NOT attempt to repair or adjust any electrical or mechanical functions on this unit, doing so will void your warranty
- Connect to properly grounded outlets only
- To reduce the risk of electrical shock, do not change the plug in any way; DO NOT use adapters

Save these instructions.

Inspection

1. Remove protective packaging.
2. Remove unit from shipping carton.
3. Remove all protective materials.
4. Check for shipping damage and loose or broken parts.
5. Read Owner's Manual thoroughly prior to installation.
6. Determine placement location for the unit (see "Operation" on page 6).

Product Features

- PCO-A (Photocatalytic Oxidation - Advanced) Technology - (1) 6" Cell Assembly
- Activated Carbon Filter
- HEPA Filter Screen
- Multiple Carbon Brushes aid in the capture of contaminants
- Purification Plate (O₃)
- Five-Speed Fan
- LED Display
- Maintenance Reminders
- Removable Rear Grill
- Universal Power Supply with Cords
- Adjustable Purification Control
- Depart Room Mode w/Adjustable Digital Timer

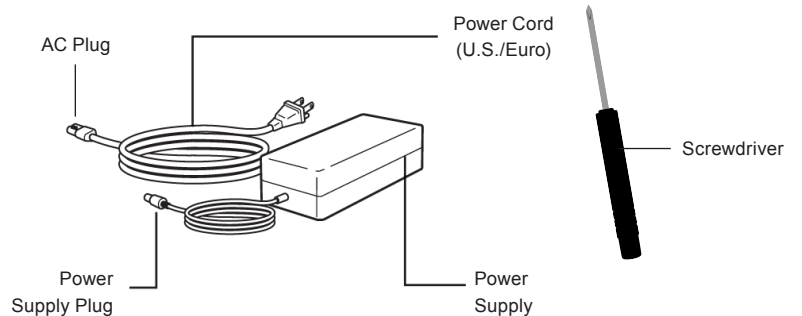
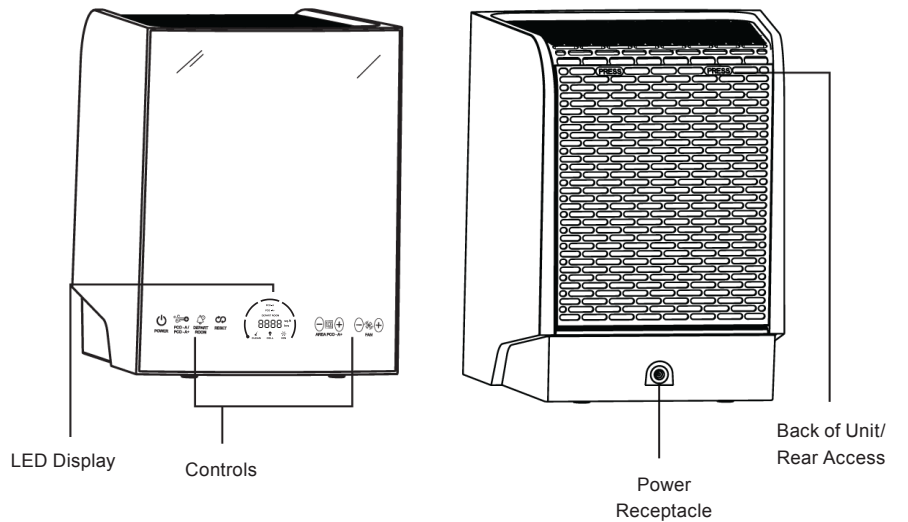

Settings & Notifications

The activTek Pure & Clean+ Ozone can be turned on or off, and adjusted, using the control panel on the front of the unit.

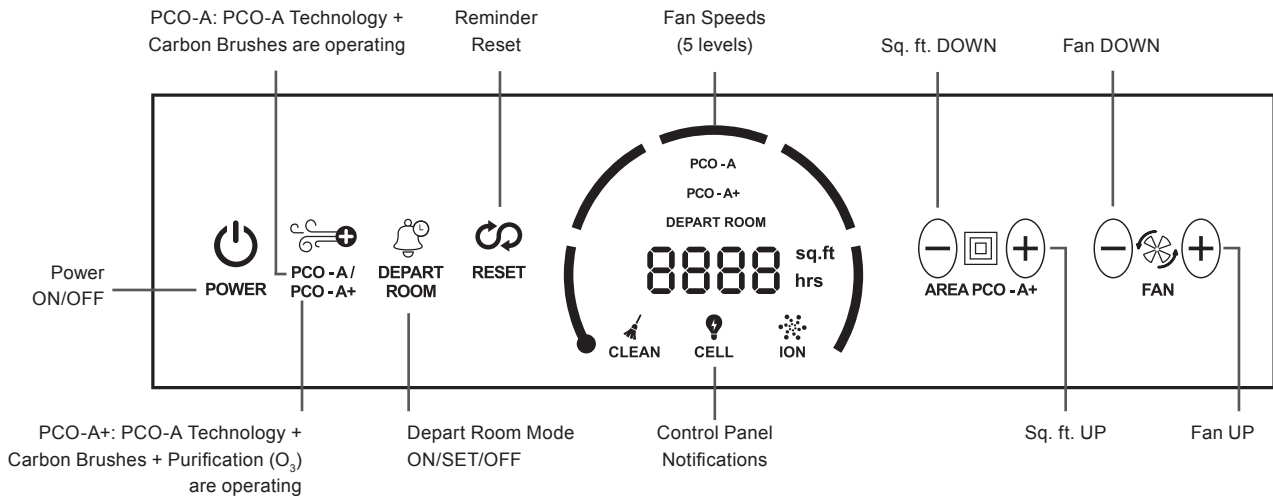

POWER (STAND BY)

Turns the unit ON and OFF.

PCO-A/PCO-A+

Toggles the unit between **PCO-A Mode** (PCO-A Technology + Carbon Brushes) and **PCO-A+ Mode** (PCO-A Technology +, Carbon Brushes + Purification (O₃)).

DEPART ROOM

Turns on and adjusts the timer for highly concentrated purification of a designated area. Each press of the **DEPART ROOM** button will change the time by 2/4/8 hours, up to eight hours, then off. **The DEPART ROOM Mode should be operated in unoccupied areas only.**

RESET

Clears the maintenance reminders after performing routine maintenance.

CLEAN

Illuminates when cleaning is required.

CELL

Illuminates to indicate the PCO-A Technology is operating. Flashes blue when it is time to replace your PCO-A Cell Assembly.

ION

Illuminates to indicate the Carbon Brushes are operating.

AREA PCO-A+

Works when unit is in **PCO-A+ Mode** to set the Purification (O₃) level for the indoor area in sq. ft. (500/1000/2000/3000).

FAN

Adjusts the 5-speed fan UP and DOWN.

NOTE: "Unoccupied areas" includes pets. Some pets, like humans, may experience adverse reactions from exposure to increased levels of ozone and should not be present during DEPART ROOM MODE operation.

LED Display

The LED Screen is used to display all current settings as well as any maintenance reminders.

If a maintenance reminder or a service reminder illuminates on the display, the backlight will brighten and constantly flash until the **RESET** icon is pressed or the service problem is corrected.

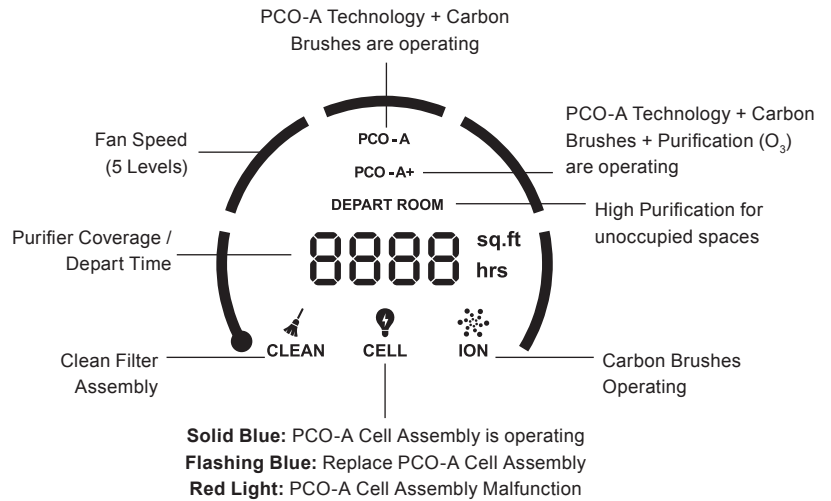

Directions for Use



- **DO NOT** operate the activTek Pure & Clean+ Ozone without the Filter Assembly and Back Cover properly installed
- **DO NOT** use Depart Room Mode in areas occupied by people or pets



- To prevent injury, be sure the Power Cord is not accessible to small children
- If you are operating your central HVAC system or other ventilation system continuously, set the coverage up to the total ventilated indoor area; otherwise, set the coverage up to the size of the room
- **DO NOT** exceed the size of the ventilated indoor area when setting the purifier level

1. Take your activTek Pure & Clean+ Ozone unit out of the shipping carton and remove all protective materials.
2. Place your unit in an appropriate location which should be four feet or higher from the ground. **Never set the unit on the floor.** Place in a location away from the HVAC return duct. The rear of the unit requires one inch or more of open area to allow unrestricted airflow.
3. Insert the Power Supply Plug into the power receptacle on the rear of the unit.
4. Insert the AC Plug on the Power Cord into the Power Supply and the other end into a working electrical outlet.
5. Push the **POWER** button once to turn the unit on. **CELL**, **ION** and **PCO-A** will illuminate on the screen. PCO-A Technology + Carbon Brushes will be operating.
6. Push the **PCO-A/PCO-A+** button once to activate the Purification (O₃) at the 500 sq. ft. setting. **CELL**, **ION** and **PCO-A+** will illuminate on the screen. PCO-A Technology + Carbon Brushes + Purification (O₃) will be operating.
7. While in **PCO-A+** Mode, push the + or - on the **PCO-A/PCO-A+** button to change the size of the area treated. The range is from 500 sq. ft. up to 3,000 sq. ft. The area chosen will display on the screen.
8. Push the **PCO-A/PCO-A+** button a second time to turn off the Purification (O₃). **CELL**, **ION** and **PCO-A** will illuminate on the screen. The PCO-A Technology + Carbon Brushes will still be operating.
9. Push the **FAN +** button four times to reach the highest speed (5th level) to initially clear the air in the room. Once the air is cleared, set to the desired fan speed. 1-5 bars will illuminate on the screen to show the corresponding fan level.
10. To operate the **DEPART ROOM** feature, in **unoccupied areas only** press the **DEPART ROOM** button until the desired time is reached (2/4/8 hours). The unit will display **DEPART ROOM** and the remaining time. To interrupt the **DEPART ROOM**, press the **PCO-A/PCO-A+** button. When the **DEPART ROOM** time is completed, the unit will turn off.

NOTE: "Unoccupied areas" includes pets. Some pets, like humans, may experience adverse reactions from exposure to increased levels of ozone and should not be present during DEPART ROOM MODE operation.

Maintenance Reminders



Unplug the unit before performing any maintenance procedures.

When maintenance is required, the Display Screen will brighten and flash and the Maintenance Reminder will appear.

CLEAN **PERFORM CLEANING**

The **CLEAN** indicator light flashes blue when the unit needs to be cleaned. The **CLEAN** indicator light will come on approximately every 40 days; for optimal performance, it is recommended to perform cleaning on your unit every 30 days

- Clean the Filter Assembly (see Page 9)
- Vacuum the PCO-A Cell Assembly
- Clean the Purification Plate (see Page 9)
- Vacuum Top and Rear Grill openings

NOTE: Be sure to press the **RESET** button to clear the reminder following regular maintenance (see section on page 8).

CELL **REPLACE PCO-A CELL ASSEMBLY**

The **CELL** indicator light will flash blue if the PCO-A Cell Assembly needs to be replaced. To order a new PCO-A Cell Assembly, please contact your Sales Representative or Customer Service at 866.736.0503 or email support@activTek.net.

For optimal performance, we recommend that you replace the PCO-A Cell Assembly every 12 months, if run 24/7/365.

If unit runs 12 hours or less per day, or less than 7 days per week, the PCO-A Cell Assembly should be changed every 24 months: or even longer if run less than that.

When the CELL indicator light flashes blue, you will need to perform the following operations:

- The **CELL** indicator light flashes blue when it's time to replace the PCO-A Cell Assembly (after 12 months of 24/7 use)
- Replace the PCO-A Cell Assembly according to the maintenance steps listed on page 12-13 of this manual
- Reset the **CELL** indicator light (see section on page 8)

When the CELL indicator light flashes red, you will need to perform the following operations:

- The **CELL** indicator light flashes red to remind the user that the PCO-A Cell Assembly is not properly installed
- Reinstall the PCO-A Cell Assembly (see pages 12-13) and check whether the bulb socket is installed properly
- Reset the **CELL** indicator light (see section on page 8)
- After performing the above operations, if the **CELL** indicator light remains flashing red, the PCO-A Cell Assembly may be damaged; In this case, please contact your Sales Representative or Customer Service at 866.736.0503 or email support@activTek.net

Maintenance Reminders (continued)



Resetting the Reminders

The reminders you need to reset are the **CLEAN** and **CELL** indicator lights. After performing maintenance, you will need to reset the indicator lights, so they can begin a new maintenance cycle. Please see instructions below for each indicator light.

- Reset the **CLEAN** indicator light with the unit plugged in, and turned on, by pressing the **RESET** button for 3-5 seconds until it beeps
- Turn the unit on and the **CLEAN** indicator light should be off
- Reset the **CELL** indicator light with the unit plugged in, but turned off, by pressing the **RESET** button for 3-5 seconds until it beeps
- Turn the unit on and the **CELL** indicator light should be off

For questions on maintenance procedures, please contact your Sales Representative or Customer Service at 866.736.0503 or email support@activTek.net.

General Maintenance

 WARNING	Unplug the unit before performing any maintenance procedures.
 CAUTION	<ul style="list-style-type: none">• Damage may result from soaking the Purification Plate longer than 10 minutes• Damage may result from using a Purification Plate when not completely dry• Use genuine activTek replacement parts only; parts from anyone other than an authorized activTek Representative may damage your unit and void your warranty

Periodic maintenance is required to ensure that your activTek Pure & Clean+ Ozone operates properly. The unit will display a **CLEAN** reminder when it's time to perform regular maintenance. If you are operating your unit in a severely polluted environment, cleaning of the unit, Purification Plate, PCO-A Cell Assembly, and Filter Assembly should be done more frequently. Shown here are basic procedures that should be carried out to keep your unit running at top performance.

NOTE: If a unit is returned for repair, and it is determined that neglect of the unit or unauthorized tampering with any mechanical or electronic component of the unit caused the failure, we reserve the right to void the product warranty. This will require the owner to pay for any required repairs.

CLEANING THE CASE

1. Wipe the unit with a soft cloth dampened (not wet) with water. Do not use chemicals or solvents.
2. Vacuum the Top and Rear Grills periodically to remove any lint buildup.

When the CLEAN indicator light flashes blue (or every 30-180 days), it's time to clean the Filter Assembly, PCO-A Cell Assembly and Purification Plate.

CLEANING THE FILTER ASSEMBLY

1. When visibly dirty, simply remove the Rear Filter Assembly from the unit (see steps 1-5 on page 10).
2. With a hand-held vacuum, remove the heavy particulate from the Filter Assembly. This method will extend the life of the Filter Assembly.
3. If the Filter Assembly can't be cleaned by vacuuming, replace the Filter Assembly.

General Maintenance (continued)

CLEANING THE PCO-A CELL ASSEMBLY

1. Remove the Rear Filter Assembly from the unit (see steps 1-5 on page 10).
2. Remove the PCO-A Cell Assembly and carefully vacuum accumulated lint.
3. **DO NOT** wash the PCO-A Cell Assembly with water. Damage from water may result.

CLEANING THE PURIFICATION PLATE

For optimal performance, the Purification Plate needs to be cleaned every few months.

1. Remove the Rear Filter Assembly from the unit (see steps 1-5 on page 10).
2. Carefully remove the Purification Plate from the card cage by grasping the middle of the edge nearest to you, and slowly pull it straight out.

NOTE: If you are in an environment where there are fats, oils, or grease, such as in a kitchen, start by cleaning with denatured alcohol and a soft bristle brush. This will cut the grease without leaving a residue.

3. **For all applications** - Clean with a mixture of one part water and one part ammonia to remove contaminants.
4. Place the Purification Plate into a shallow dish, and pour enough of the water/ ammonia solution into the dish to just cover plate.
5. Allow the Purification Plate to soak for no more than 10 minutes.
6. Remove the Purification Plate and scrub with a soft bristle brush.
7. Rinse thoroughly with warm water.
8. Let air-dry for 24 hours or use a blow dryer to dry thoroughly.

NOTE: Using a Purification Plate that is NOT completely dry may damage the plate.

REPLACING THE FILTER ASSEMBLY

1. For optimal performance and to maintain the product warranty: Replace the Filter Assembly with a genuine activTek filter every (12) months if run 24/7/365; if run 12 hours or less per day, the filter should be changed every (24) months.
2. To replace the Filter Assembly, please follow the instructions on pages 10-11.

NOTE: Filter Assembly life will vary based on the operating environment.

REPLACING THE PCO-A CELL ASSEMBLY

1. For optimal performance and to maintain the product warranty: Replace the PCO-A Cell Assembly with a genuine activTek part every (12) months if run 24/7/365; if run 12 hours or less per day, the PCO-A Cell Assembly should be changed every (24) months.
2. To replace the PCO-A Cell Assembly, please follow the instructions on pages 12-13.

REPLACING THE PURIFICATION PLATE

1. For optimal performance and to maintain the product warranty: Replace the Purification Plate with a genuine activTek part every (12) months if run 24/7/365; if run 12 hours or less per day, the Purification Plate should be changed every (24) months.
2. To replace the Purification Plate, please follow the instructions on pages 12-13.

NOTE: You will notice a lack of ozone (O₃) production when the Purification Plate is at the end of its life.

Filter Assembly

activTek filter technology makes the activTek Pure & Clean+ Ozone incredibly quiet. Units come with one Filter Assembly and an optional HEPA Filter Sheet (installed).

The Filter Assembly filters out airborne particles (dust, pollen, pet dander, mold spores, and other airborne particles). To maximize filter effectiveness, particles are negatively charged before reaching the filter.

For optimal performance we recommend that you replace the Filter Assembly every 12 months if run 24/7/365.

If run 12 hours or less per day, the Filter Assembly should be changed every 24 months.

Replacing the Filter Assembly



- **Unplug the unit before performing any maintenance procedures**
- **DO NOT** operate the activTek Pure & Clean+ Ozone without the Filter Assembly and Back Cover properly installed



Use genuine activTek replacement parts only; parts from anyone other than an authorized activTek Representative may damage your unit and void your warranty.

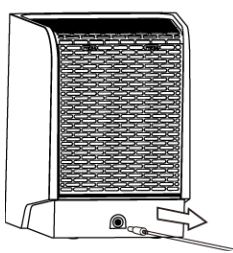

1. Unplug the unit from the power source.

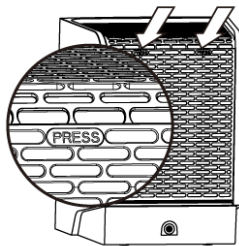

2. Press the top of the Back Cover to release the back panel.

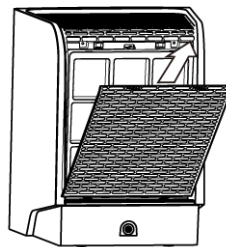

3. Lift up to remove the back panel

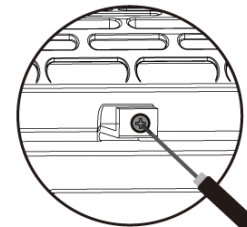

4. Use the included screwdriver to unscrew the Filter Assembly.

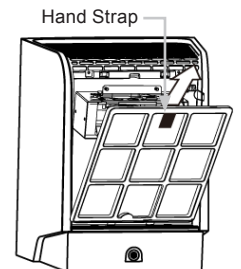

5. Lift the Filter Assembly up and out to remove.

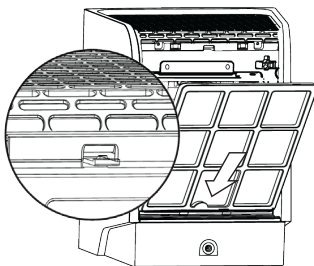

6. Install the new Filter Assembly by inserting at the bottom.

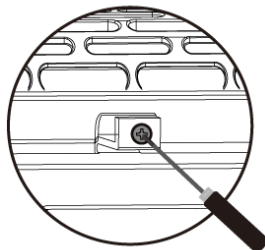

7. Use the included screwdriver to secure the Filter Assembly.

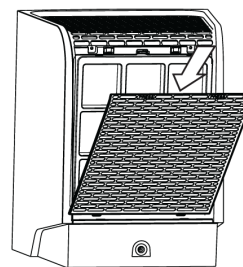

8. Place the Back Cover on by inserting the bottom of the Back Cover first.

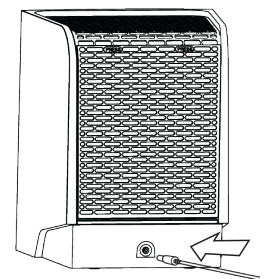

9. Plug the unit into the electrical outlet and turn the power on.

Removing the Optional HEPA Filter Sheet



Unplug the unit before performing any maintenance procedures.

The Optional HEPA Filter Sheet is designed specifically for areas with tobacco smoke, multiple pets, or anywhere contaminants in the air could be prevalent.

- Protects your unit from indoor contaminants, which may shorten the life of your product
- Reduces monthly maintenance and cleaning time up to 90%
- Helps reduce odors
- Great in kitchen environments
- Helps reduce VOC gases and other contaminants

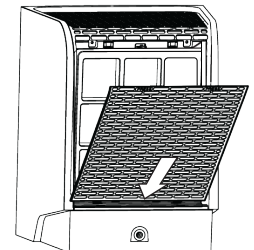
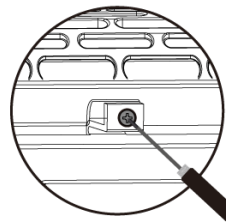
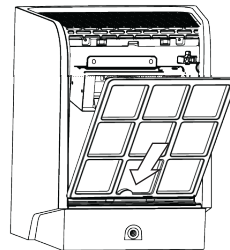
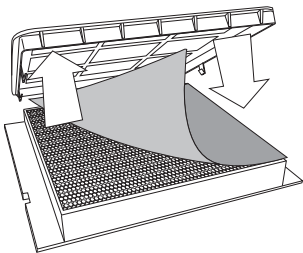

1. Remove the Rear Filter Assembly (see steps 1-5 on page 10).
2. Remove the Optional HEPA Filter Sheet on top of the Prefilter.
3. Replace the Filter Assembly, inserting the bottom of the Filter Assembly first.
4. Use the included screwdriver to screw in the Filter Assembly.
5. Place the Back Cover by inserting the bottom in first and snapping into place.

NOTE: Removing the Optional HEPA Filter Sheet will increase the airflow of the unit.

PCO-A Cell Assembly

Our proprietary PCO-A Cell Assembly that is found in the activTek Pure & Clean+ Ozone uses PCO-A Technology to produce molecules that inactivate contaminants found in the air in indoor spaces.

For optimal performance we recommend that you replace the PCO-A Cell Assembly every 12 months if run 24/7/365. If run 12 hours or less per day, or less than 7 days per week, the PCO-A Cell Assembly should be changed every 24 months; or even longer if run less than that.

Replacing the Purification Plate & PCO-A Cell Assembly



- Unplug the unit before performing any maintenance procedures
- **DO NOT** look directly at the glowing lamp. Prolonged exposure, even to reflected UV light, can cause eye damage according to the American Conference of Governmental Industrial Hygienists (ACGIH) Standards
- **DO NOT** operate the activTek Pure & Clean+ Ozone without the Filter Assembly and Back Cover properly installed



- For optimal performance and to maintain the limited 3 year warranty, it is required to replace the PCO-A Cell Assembly every year, even if the PCO-A Cell appears to be operating normally
- Use genuine activTek replacement parts only; parts from anyone other than an authorized activTek Representative may damage your unit and void your warranty

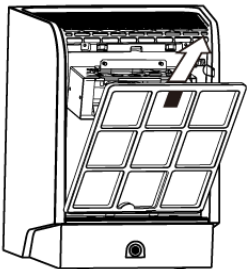

1. Remove the Filter Assembly (see steps 1-5 on page 10).

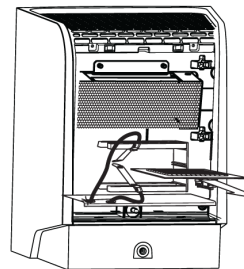

2. To remove the Purification Plate, grasp edge of plate in the center and gently pull out.

NOTE: If the Purification Plate is difficult to remove, gently press down on the lower metal contact tab.

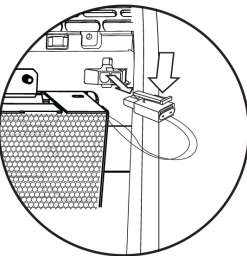

3. To remove the PCO-A Cell Assembly, unlock the Connector by pressing on the Connector's locking tabs.

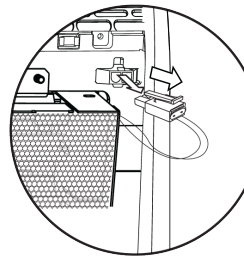

4. Pull the Connector straight out to unplug.

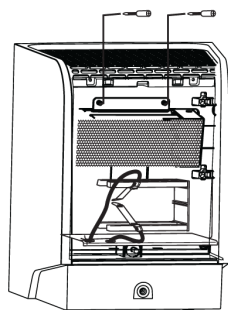

5. Remove the two (2) thumbscrews from the PCO-A Cell Assembly.

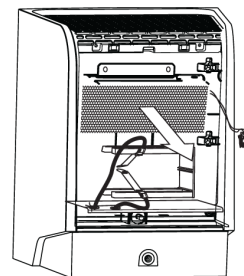

6. Slide the PCO-A Cell Assembly down and out of unit.

Replacing the Purification Plate & PCO-A Cell Assembly (cont.)

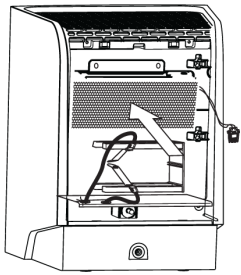

7. Slide the new PCO-A Cell Assembly up and into the unit.

NOTE: Be sure the back lip of the PCO-A Cell Assembly engages the two slotted protrusions at the rear of the plate cage, and that the angle brackets and studs are correctly aligned.

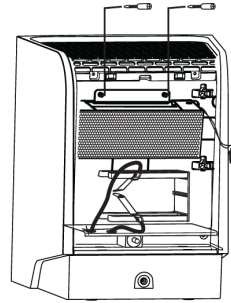

8. Insert the two thumbscrews and tighten. Insert the PCO-A Cell Assembly Connector into the plug on the plate cage.

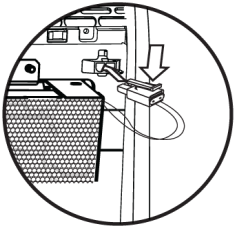

9. Press the Connector firmly until the two tabs lock into place.

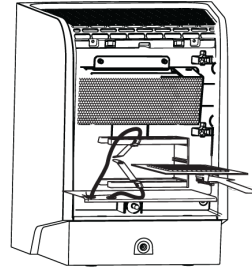

10. Gently insert the Purification Plate between the guides (inside the cage) until it stops.

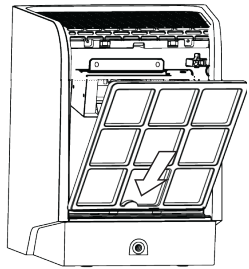

11. Replace the Filter Assembly, inserting the bottom of the Filter Assembly first.

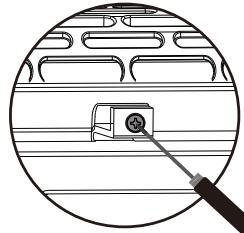

12. Use the included screwdriver to screw in the Filter Assembly.

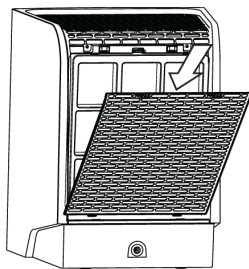

13. Replace the Back Cover by inserting the bottom in and snapping into place.



Visit lamprecycle.org for proper bulb disposal regulations

For questions on maintenance procedures, please contact your Sales Representative or Customer Service at 866.736.0503 or email support@activTek.net.

Troubleshooting

INDICATORS OF OPERATION

When the unit is on, the LED display will show either the Fan setting and **PCO-A**, or the Fan setting, Purification setting (**PCO-A+**), and square footage. If the unit is in Depart Room, it will display **DEPART ROOM** plus the hours and minutes remaining (see page 5 for more information).

TROUBLESHOOTING — WHAT TO LOOK FOR FIRST

1. I have plugged in the unit, pressed the ON button on the activTek Pure & Clean+ Ozone, and nothing happens.

What's wrong?

- Make sure the Power Cord is inserted completely into the receptacle on the back of the unit
- Make sure the electrical outlet is capable of providing power to the unit
- Check the Filter Assembly seating, as it engages a safety switch which turns off the unit

2. The fan is operating but the Purification Plate is not working. What's wrong?

- The unit is in **PCO-A** Mode (press the **PCO-A/PCO-A+** switch to change to **PCO-A+** Mode)
- Check the Purification Plate for serviceability; if it is cracked or broken, the Purification Plate will require replacement
- Ensure maintenance procedures required for the Purification Plate have been performed according to the "Maintenance" section of this Owner's Manual. Order new Purification Plates from your Sales Representative or Customer Service.

3. The Purification Plate is making a noise, has a burning smell, and/or appears to arc or spark. What is the problem?

- The Purification Plate is most likely cracked
- Refer to the answers for question# 2, as it would apply to this question also

4. The PCO-A Cell Assembly is not functioning/I'm getting a replace CELL Message.

- Check PCO-A Cell Assembly for proper installation
- Replace the PCO-A Cell Assembly

5. What are the most typical application problems?

- **Symptom:** A belief that the proper equipment is placed in the environment and the equipment appears unsuccessful
- **Problem:** Lack of air movement, improper placement of the unit
- **Symptom:** Strong odors still remain within the environment after placement
- **Problem:** Purification setting is too low, improper placement of the unit, or the source of the odor has not been eliminated
- **Symptom:** A strong odor of ozone is present within the environment
- **Problem:** Too much ozone accumulation within the environment as a result of improper Purification control setting, and/or lack of air movement
- **Symptom:** Visual haze of smoke and/or particulate remain within the environment
- **Problem:** No air movement/Carbon Brushes not operating

6. Air flow is restricted or reduced

- Is the unit properly placed away from objects that may obstruct air flow?
- Are the Filter Assembly, Back Cover, and Top and Rear Grill clean?
- Is the PCO-A Cell Assembly clean?

7. How can I tell if the PCO-A Cell Assembly is functioning?

- The PCO-A Cell Assembly will produce a glow that is visible through the Top and Rear Grill under low light conditions

8. Unit does not operate.

- Is the unit plugged in?
- Are you sure the electrical outlet is active?
- Are the Filter Assembly and Back Cover installed properly?

For questions on troubleshooting, please contact your Sales Representative or Customer Service at 866.736.0503 or email support@activTek.net.

Replacement Parts



Use genuine activTek replacement parts only; Parts from anyone other than an authorized activTek Representative may damage your unit and void your warranty.

REPLACEMENT PARTS	PART NUMBER
PCO-A Cell Assembly – (1) 6" Cell Assembly	9950240 or 50106
Purification Plate (O ₃) Not available in California or Canada	9950239 or 50109
Filter Assembly	9950238 or 50107
Power Supply with U.S./Euro Plug	9950242 or 50108

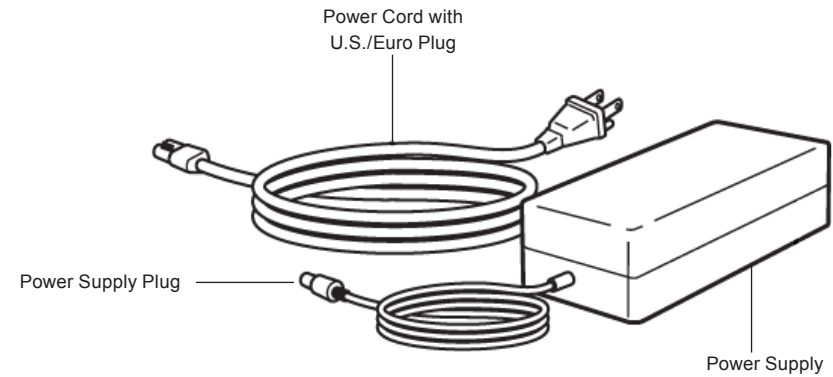
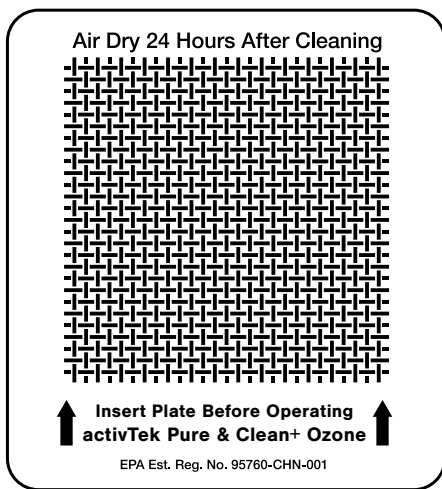
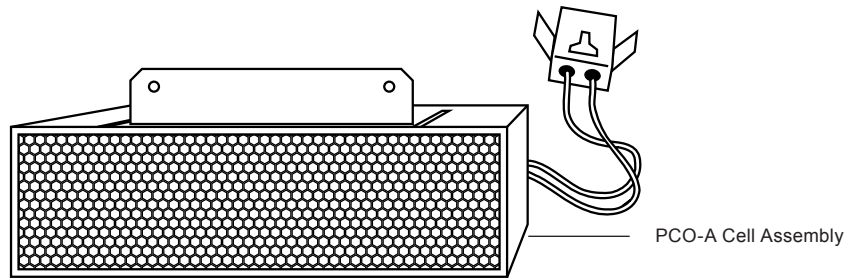
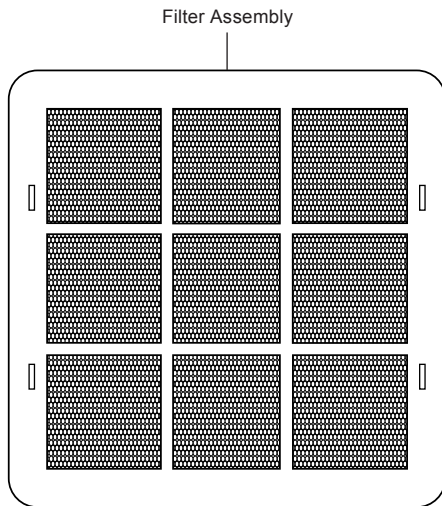

Purification Plate
(NOT available in California or Canada)

To order replacement parts, please contact your Sales Representative or Customer Service at 866.736.0503 or email support@activTek.net.

Warranty Information

Limit Three (3) Year Warranty

To register your activTek Pure & Clean+ Ozone unit, please contact Customer Service at 866.736.0503 or email support@activTek.net.

Customer should not repackage and ship the activTek Pure & Clean+ Ozone unit due to possibility of irreparable damage. For questions on warranty service, please contact Customer Service at 866.736.0503 or email support@activTek.net.

WHAT IS COVERED BY THIS WARRANTY

We warrant the activTek Pure & Clean+ Ozone (excluding filters) to the customer, subject to the conditions below, against defects in workmanship or material, provided that the products are returned to an authorized activTek location within the following time periods:

- activTek Pure & Clean+ Ozone (excluding the Filter Assembly and PCO-A Cell Assembly) within three (3) years from date of purchase
- PCO-A Cell Assembly (Qty 1) within (12) months from date of purchase
- Purification Plate (Qty 1) within (12) months from date of purchase

MAINTENANCE REQUIREMENTS

This warranty is expressly conditioned upon proper, operation, cleaning and maintenance, all in accordance with the Owner's Manual. Failure to meet any of these requirements will void this warranty. Servicing of your activTek Pure & Clean+ Ozone by parties other than an authorized activTek Representative and/or using parts other than genuine activTek parts will also void this warranty.

This warranty is contingent upon:

- Registration of the product through the approved methods listed above
- Replacing the PCO-A Cell Assembly with a genuine activTek part once every (12) months if run 24/7/365. If run 12 hours or less per day, the PCO-A Cell Assembly should be replaced every 24 months (proof of change may be required)
- Cleaning the Filter Assembly every 30-180 days (according to instructions in Owner's Manual)
- Replacing the Filter Assembly with a genuine activTek filter every (12) months if run 24/7/365; if run 12 hours or less per day, the filter should be changed every (24) months (proof of change may be required)
- Replacing the Purification Plate with a genuine activTek part once every (12) months Proof of change may be required)

HOW TO OBTAIN WARRANTY SERVICE

Customer must register their product by contacting Customer Service at 866.736.0503 or email support@activTek.net and provide proof of purchase (including purchase date) within the above time periods. We will repair or replace and return the product, without charge and within a reasonable period of time, subject to the conditions herein, if its examination shall disclose any part to be defective in workmanship or material. If we, in our discretion, are unable to repair the product after a reasonable number of attempts, we will provide either a refund of the purchase price or a replacement unit, at the company's option.

WHAT IS NOT COVERED BY THIS WARRANTY

Ordinary wear and tear shall not be considered a defect in workmanship or material. These warranties do not apply to filters nor to loss or damage caused by accident, fire, abuse, misuse, improper installation, modification, misapplication, failure to maintain the product as provided herein, or by any repairs other than those provided by our authorized activTek location. This warranty is non-transferable.

UNAUTHORIZED CHANNELS AND MISSING SERIAL NUMBERS

If a valid serial number is missing from the product, the warranty will be voided. activTek products are authorized for sale through activTek Sales Representatives only. Warranties are voided if a product is purchased through unauthorized channels; this includes websites that are not authorized to sell our products OR use activTek's trademarked names, images and logos as well as Internet auction sites (e.g. eBay and Craigslist). The only approved Internet presence for activTek products is activTek.net. To confirm warranty coverage prior to purchasing a product, please contact Customer Service at 866.736.0503 or email support@activTek.net with the serial number located on the unit.

EXCLUSION OF OTHER WARRANTIES AND CONDITIONS

EXCEPT AS PROVIDED HEREIN, AND TO THE EXTENT CONSISTENT WITH APPLICABLE LAWS, WE MAKE NO REPRESENTATION OR WARRANTY OF ANY KIND. ALL OTHER WARRANTIES OF ANY KIND, EXPRESS OR IMPLIED, ARE HEREBY EXPRESSLY DISCLAIMED, INCLUDING ANY IMPLIED WARRANTY OF MERCHANTABILITY OR FITNESS FOR A PARTICULAR PURPOSE.

LIMITATION OF LIABILITY FOR SPECIAL, INCIDENTAL, OR CONSEQUENTIAL DAMAGES

TO THE EXTENT CONSISTENT WITH APPLICABLE LAWS, WE SHALL NOT IN ANY CASE BE LIABLE FOR SPECIAL, INCIDENTAL OR CONSEQUENTIAL DAMAGES ARISING FROM BREACH OF EXPRESSED OR IMPLIED WARRANTIES, CONDITIONS, GUARANTEES OR REPRESENTATIONS, BREACH OF CONTRACT, NEGLIGENCE OR ANY OTHER LEGAL THEORY. Such excluded damages include, but are not limited to, loss of profits or revenue, and loss of the use of the products.

FOR U.S. APPLICATION ONLY

This warranty gives you specific legal rights, and you may also have other rights which vary from state to state. Some states do not allow limitations on warranties, or on remedies for breach. In such states, the above limitations may not apply to you.

This warranty is provided by:

activTek Environmental, LLC
1300 Valley Drive
Bristol, VA 24201

SERVICE

Every effort is made to ensure customers receive an up-to-date owner's manual on the use of our products; however, from time to time, modifications to our products may without notice make the information contained herein subject to alteration. For the latest information, please view the owner's manual at activTek.net/manuals.

FCC Declaration & Responsible Party

This equipment has been tested and found to comply with the limits for a Class B digital device, pursuant of part 15 of the FCC Rules. These limits are designed to provide reasonable protection against harmful interference in a residential installation. This equipment generates, uses, and can radiate radio frequency energy, and if not installed and used in accordance with the instructions, may cause harmful interference to radio communications. However, there is no guarantee that interference will not occur in a particular installation. If this equipment does cause harmful interference to radio or television, which can be determined by turning the equipment off and on, the user is encouraged to try to correct the interference by one or more of the following measures:

- Reorient or relocate the receiving antenna.
- Increase the separation between the equipment and receiver.
- Connect the equipment into an outlet on a circuit different from that to which the receiver is connected.
- Consult the Independent Contractor for help.

FCC DECLARATION OF CONFORMITY

Name: activTek Pure & Clean+ Ozone

Model: A1041A

Produced for: activTek Environmental, LLC

This device complies with Part 15 of the FCC Rules.

RESPONSIBLE PARTY

activTek Environmental, LLC

1300 Valley Drive

Bristol, VA 24201

Ph: 866.736.0503

Signature: 

Printed Name: Andrew Eide

Title: Chief Technology, Product
& Regulatory Officer

Date: 02/13/2026

For information regarding the use of this product, please contact Customer Service at 866.736.0503 or email support@activTek.net

ACTIVTEK.NET

© 2025 activTek Environmental, LLC. All Rights Reserved

